



## Otero County Electric Cooperative, Inc.

A Touchstone Energy® Cooperative 

404 Burro Avenue  
PO Box 227  
Cloudcroft, NM 88317

---

### NEW SERVICE CONTACT LIST

**Any questions** regarding the procedures, progress of the new service, equipment or the contract package should be directed to our **Staking Department only**. Please contact the following OCEC employees listed below:

#### Cloudcroft/Southern Area

- Courtney Auld                    575-682-2521 ext 626 or email courtneya@ote-coop.com
- Lance Wright                    575-682-2521 ext 624

#### Alto & Carrizozo/Northern Area

- Courtney Auld                    575-682-2521 ext 626 or email courtneya@ote-coop.com
- Dakota Grinder                    575-336-4550 ext 404

Thank you and welcome to Otero County Electric Cooperative, Inc. We look forward to serving you.



## Otero County Electric Cooperative, Inc.

### New Service Procedures Estimates & Application

The following procedure describes the steps necessary to obtain electric service from Otero County Electric Cooperative (OCEC) in an efficient and timely manner. Because this process can be complex, we have developed this procedure to make your request for service as simple as possible.

#### **STEP 1: Apply for Electric Service**

Attached to this procedure, you will find OCEC's New Service Application. Complete this application and return it to the closest OCEC office. **This application is not complete without the full legal description and a \$50.00 estimate fee per each service and/or lot estimated. (Note: For line extensions longer than ¼ mile, the estimate fee will be an additional \$50.00 per ¼ mile).** All estimates are valid for 60 days and are non-refundable. Please also include any additional information you can provide including desired line location, maps, final plats (required for developers), and any special power requirements. Our Staking Department will use this information to make an initial on-site visit and evaluate what construction will be required for your new electric service.

The OCEC Staking Department will then provide you with an estimate for the required construction less any applicable credits. One credit will be applied to each "permanent service" as defined by OCEC's Line Extension Policy. If temporary construction power is required, you will be eligible for a construction credit if permanency has been established within 12 months from the connect date. It is your responsibility to notify OCEC about permanency, at which time OCEC will verify and apply the credit. You may also receive a credit for a well that will eventually serve a residence. In both instances, it is your responsibility to notify OCEC when the residence has been established to be billed in the appropriate rate class.

#### **STEP 2: Complete Contract Package**

Upon receipt of OCEC's estimate, you must request a contract package if you wish to proceed with the new service, and provide the most recent copy of the warranty deed. OCEC's Contract Representative will assemble and mail you a contract package, which will include all contracts, easement forms, and other required documentation. It is your responsibility to acquire all necessary easements. **The contract package must be returned to OCEC, along with payment for construction within 60 days to remain valid.**

#### **STEP 3: Meter Loop Installation & Permitting**

You are now ready for a New Mexico licensed electrician to install your meter loop. OCEC's Staking Department will stake the final construction route once you have notified us the meter loop is installed. It is your electrician's responsibility to file all required permits with the city, state, or applicable government agency. Upon completion of the meter loop installation, the state or city electrical inspector must give OCEC approval of the installation before we will schedule construction. Once we have received this approval, we will schedule construction and build the job. **Customer need not be present during construction.**



## Summary Checklist

1. Consumer submits completed application with the full legal description, description of desired meter location on the property, and \$50.00 estimate fee per lot or service.
2. Staking Department will look at the location of the request and call consumer with construction estimate.
3. Consumer requests a contract package from the Staking Department based on the construction estimate, and provide the most current copy of the warranty deed.
4. Contract Representative will assemble Contract Package (Contract, Easement Forms, Connect Sheets, etc.) and either mail or call consumer when ready for pickup.
5. Consumer returns Contract Package (signed and notarized) along with payment for connection and construction.
6. Consumer has NM licensed electrician install meter pole and/or meter loop at which time your electrician will file required permits with city or state.
7. State or City Inspector inspects and submits approval to OCEC Contract Representative.
8. Staking Department designs and stakes the final construction layout. Upon completion of staking, the Staking Department will call New Mexico One-Call, which initiates a two-day hold, providing a window for all underground utilities to be located.
9. Staking Department turns job over to Operations Department upon expiration of New Mexico One-Call two-day hold period.
10. Operations Department schedules the construction.
11. Line crews construct required power lines and connect the electric service. Customer need not be present.
12. You have electric service!

**NOTE: The steps above must be done in order. While you may have your electrician install the meter pole and/or meter loop sooner, OCEC strongly suggests completion of the Contract Package first to prevent potential easement problems.**

A Touchstone Energy<sup>®</sup> Cooperative





# New Service Application

Today's Date: \_\_\_\_\_

## 1. CUSTOMER CONTACT INFORMATION:

Estimate Fee Paid:  Yes  No

Name(s): \_\_\_\_\_

Mailing Address: \_\_\_\_\_

City: \_\_\_\_\_ State: \_\_\_\_\_ Zip: \_\_\_\_\_

Home Phone: \_\_\_\_\_ Cell Phone: \_\_\_\_\_ Work Phone: \_\_\_\_\_

E-Mail Address: \_\_\_\_\_

## 2. SERVICE LOCATION INFORMATION:

Physical Address: \_\_\_\_\_

City: \_\_\_\_\_ State: \_\_\_\_\_ County: \_\_\_\_\_

Subdivision: \_\_\_\_\_ Unit: \_\_\_\_\_ Block: \_\_\_\_\_ Lot: \_\_\_\_\_

Section: \_\_\_\_\_ Township: \_\_\_\_\_ Range: \_\_\_\_\_ Quarters: \_\_\_\_\_

## 3. SITE INFORMATION:

Single Family Home  Manufactured Home  Well Preferred Build:  Overhead  Underground

Stage of Construction:  Staked  Foundation Poured  Under Roof  120/240 Volts  Other: \_\_\_\_\_ Volts

Do you need temporary power during construction?  Yes  No Heated/Cooled Square Footage: \_\_\_\_\_

Irrigation Well

Horse Power: \_\_\_\_\_ Requirements:  Single-Phase  Three-Phase Voltage: \_\_\_\_\_ / \_\_\_\_\_

Commercial/Other: \_\_\_\_\_

## 4. LOAD REQUIREMENTS:

Main Disconnect Size:  100 amp  200 amp  Other: \_\_\_\_\_ amps Electric Heating:  Yes  No

Electric Water Heater:  Yes  No A/C:  Evaporative  Refrigerated: \_\_\_\_\_ Tons  None

Additional Equipment (water well, swimming pool, hot tub, shop equipment, etc) \_\_\_\_\_

**Please include a copy of the property warranty deed, description of desired meter location on property, and \$50 estimate fee (estimate & estimate fee valid for 60 days after delivery of contract). Application will be considered incomplete without these items.**

I understand it is my responsibility to read and adhere to OCEC's New Service Procedures.

Signature: \_\_\_\_\_ Date: \_\_\_\_\_

Construction to be done: \_\_\_\_\_

Minimum \$ \_\_\_\_\_ Construction Cost \$ \_\_\_\_\_ Connect Fee \$ \_\_\_\_\_

- \_\_\_\_\_ 1. Consumer submits completed application, copy of the property warranty deed, description of desired meter location on the property, and \$50 estimate fee per lot or service.  
**NOTE: Multiple estimate routes, locations or types (examples) overhead & underground, will incur multiple \$50.00 estimate fees.**
- \_\_\_\_\_ 2. Staking Department will look at the location of the request and call consumer with construction estimate.  
**NOTE: All required easements are the consumer's responsibility.**
- \_\_\_\_\_ 3. Consumer requests a contract package from the Staking Department based on the construction estimate.
- \_\_\_\_\_ 4. Contract Representative will assemble Contract Package (Contract, Easement Forms, Connect Sheets, etc.) and either mail or call consumer when ready for pickup.
- \_\_\_\_\_ 5. Consumer returns Contract Package (signed & notarized) along with payment for connection and construction.
- \_\_\_\_\_ 6. Consumer has NM licensed electrician install meter pole and/or meter loop at which time your electrician will file required permits with city or state.
- \_\_\_\_\_ 7. State or City Inspector inspects and submits approval to OCEC Contract Representative.
- \_\_\_\_\_ 8. Staking Department designs and stakes the final construction layout. Upon completion of staking, the Staking Department will call New Mexico One-Call, which initiates a two day hold, providing a window for all underground utilities to be located.
- \_\_\_\_\_ 9. Staking Department turns job over to Operations Department upon expiration of New Mexico One-Call two day hold period (by law).
- \_\_\_\_\_ 10. Operations Department schedules the construction.
- \_\_\_\_\_ 11. Line Crews construct required power lines and connect the electric service. Customer need not be present.
- \_\_\_\_\_ 12. You have electric service!

# OTERO COUNTY ELECTRIC COOPERATIVE METER POLE SPEC SHEET

METER POLE SHALL NOT BE INSTALLED WITHIN 15' OF CENTERLINE OF OCEC POWER LINES OR EQUIPMENT

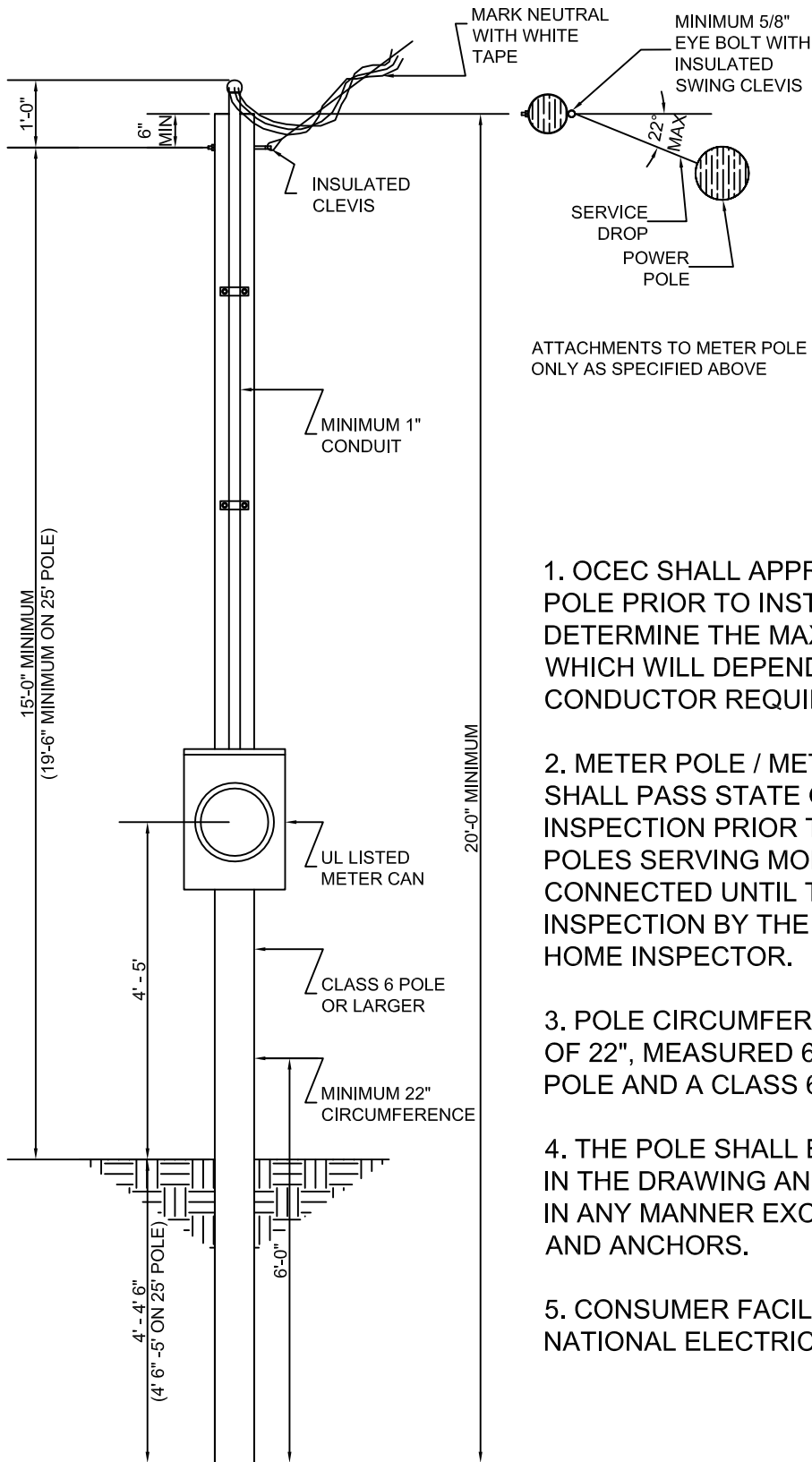

ATTACHMENTS TO METER POLE ONLY AS SPECIFIED ABOVE

1. OCEC SHALL APPROVE LOCATION OF METER POLE PRIOR TO INSTALLATION. OCEC SHALL DETERMINE THE MAXIMUM SERVICE DISTANCE, WHICH WILL DEPEND ON CLEARANCE, CONDUCTOR REQUIREMENTS AND LOAD.
2. METER POLE / METER LOOP INSTALLATION SHALL PASS STATE OR LOCAL ELECTRICAL INSPECTION PRIOR TO CONNECTION. METER POLES SERVING MOBILE HOMES WILL NOT BE CONNECTED UNTIL THE MOBILE HOME PASSES INSPECTION BY THE STATE OR LOCAL MOBILE HOME INSPECTOR.
3. POLE CIRCUMFERENCE SHALL BE A MINIMUM OF 22", MEASURED 6' FROM THE BUTT OF THE POLE AND A CLASS 6 POLE OR LARGER.
4. THE POLE SHALL BE SET TO DEPTH SHOWN IN THE DRAWING AND SHALL NOT BE BRACED IN ANY MANNER EXCEPT OCEC APPROVED GUY AND ANCHORS.
5. CONSUMER FACILITIES SHALL COMPLY WITH NATIONAL ELECTRIC CODE.

OVERHEAD PERMANENT/TEMPORARY SINGLE-PHASE OR  
TEMPORARY THREE-PHASE SERVICE POLE

OTERO COUNTY ELECTRIC COOPERATIVE  
METER ON BUILDING SPEC SHEET

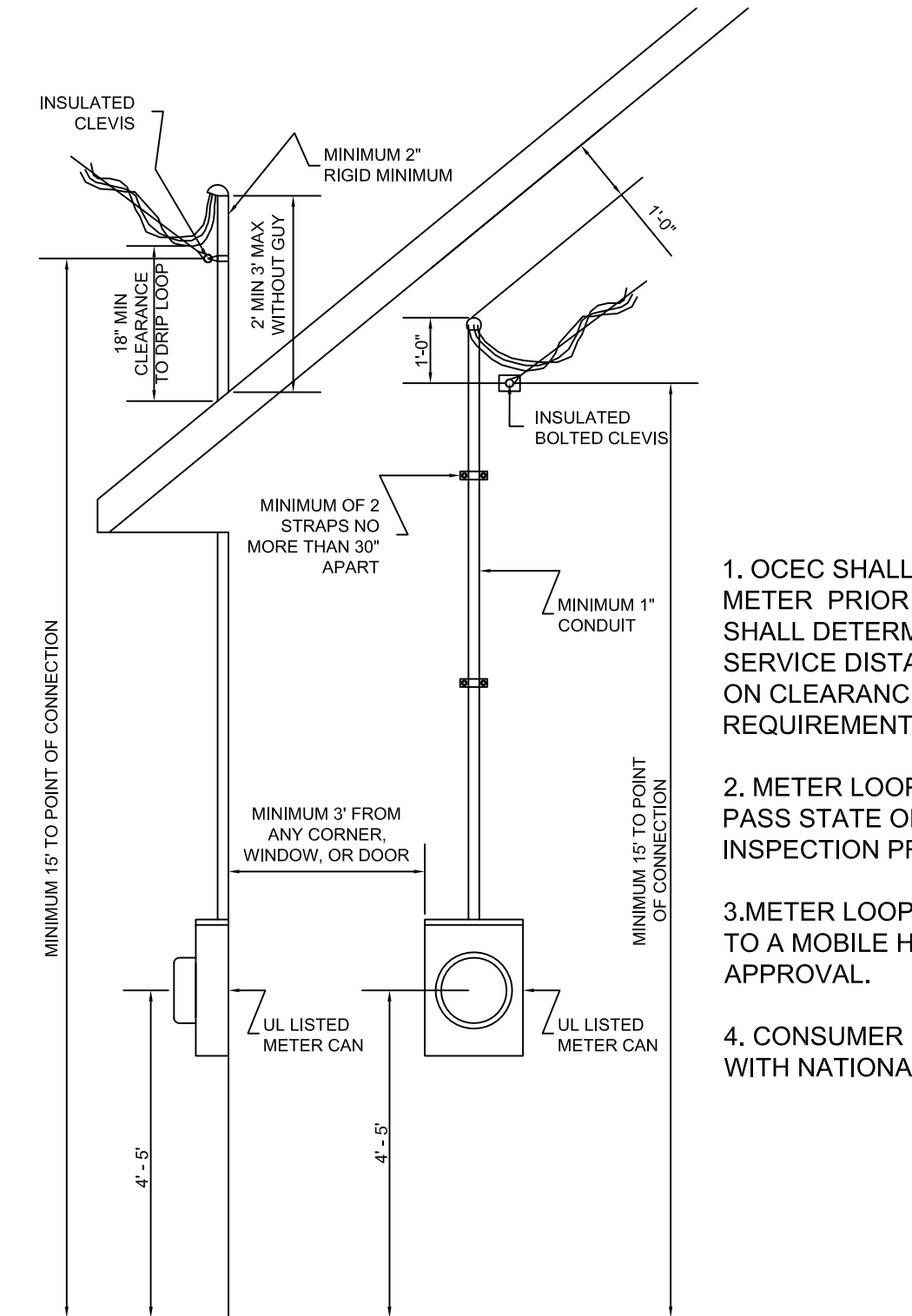

1. OCEC SHALL APPROVE LOCATION OF METER PRIOR TO INSTALLATION. OCEC SHALL DETERMINE THE MAXIMUM SERVICE DISTANCE, WHICH WILL DEPEND ON CLEARANCE, CONDUCTOR REQUIREMENTS AND LOAD.

2. METER LOOP INSTALLATION SHALL PASS STATE OR LOCAL ELECTRICAL INSPECTION PRIOR TO CONNECTION.

3. METER LOOPS MAY NOT BE ATTACHED TO A MOBILE HOME WITHOUT ENGINEER'S APPROVAL.

4. CONSUMER FACILITIES SHALL COMPLY WITH NATIONAL ELECTRIC CODE.

OVERHEAD PERMANENT SINGLE-PHASE SERVICE CONNECTION  
TO A PERMANENT BUILDING



# OTERO COUNTY ELECTRIC COOPERATIVE URD METER PEDESTAL SPEC SHEET

METER PEDESTAL SHALL NOT BE INSTALLED WITHIN 15' OF  
CENTERLINE OF OCEC POWER LINES

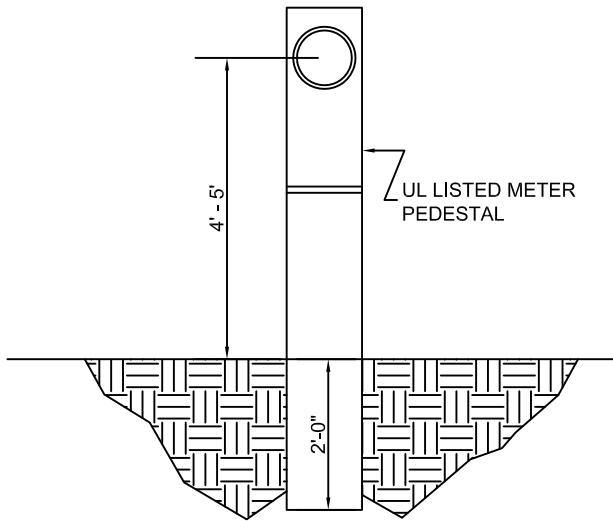

1. OCEC SHALL APPROVE LOCATION OF METER PEDESTAL PRIOR TO INSTALLATION. OCEC SHALL DETERMINE THE MAXIMUM SERVICE DISTANCE, WHICH WILL DEPEND ON CLEARANCE, CONDUCTOR REQUIREMENTS AND LOAD.

2. METER PEDESTAL INSTALLATION SHALL PASS STATE OR LOCAL ELECTRICAL INSPECTION PRIOR TO CONNECTION. METER PEDESTALS SERVING MOBILE HOMES WILL NOT BE CONNECTED UNTIL THE MOBILE HOME PASSES INSPECTION BY THE STATE OR LOCAL MOBILE HOME INSPECTOR.

3. CONSUMER FACILITIES SHALL COMPLY WITH NATIONAL ELECTRIC CODE.

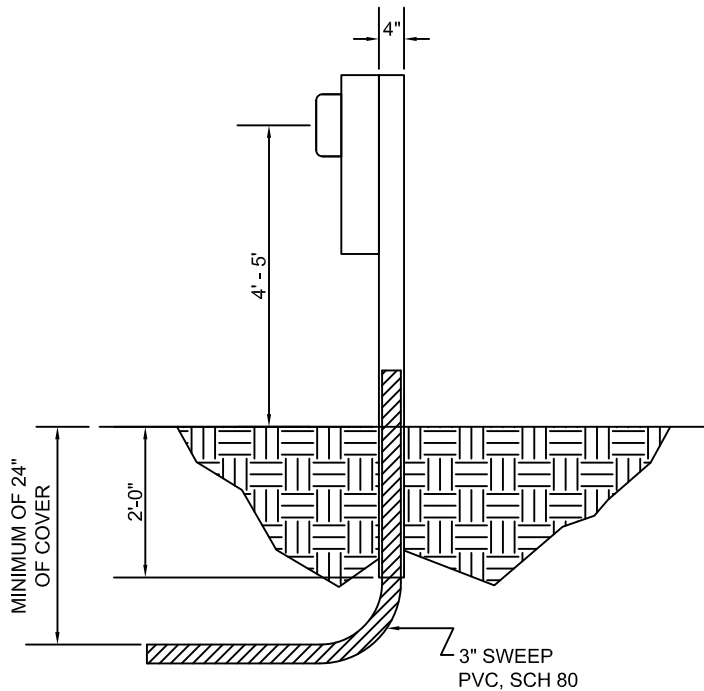

UNDERGROUND PERMANENT/TEMPORARY  
SINGLE-PHASE SERVICE

# OTERO COUNTY ELECTRIC COOPERATIVE URD METER POLE SPEC SHEET

METER POLE SHALL NOT BE INSTALLED WITHIN 15' OF  
CENTERLINE OF OCEC POWER LINES OR EQUIPMENT

1. OCEC SHALL APPROVE LOCATION OF METER POLE PRIOR TO INSTALLATION. OCEC SHALL DETERMINE THE MAXIMUM SERVICE DISTANCE, WHICH WILL DEPEND ON CLEARANCE, CONDUCTOR REQUIREMENTS AND LOAD.

2. METER POLE / METER LOOP INSTALLATION SHALL PASS STATE OR LOCAL ELECTRICAL INSPECTION PRIOR TO CONNECTION. METER POLES SERVING MOBILE HOMES WILL NOT BE CONNECTED UNTIL THE MOBILE HOME PASSES INSPECTION BY THE STATE OR LOCAL MOBILE HOME INSPECTOR.

3. POLE CIRCUMFERENCE SHALL BE A MINIMUM OF 22", MEASURED 6' FROM THE BUTT OF THE POLE AND A CLASS 6 POLE OR LARGER. POLE MUST BE TREATED.

4. THE POLE SHALL BE SET TO DEPTH SHOWN IN THE DRAWING AND SHALL NOT BE BRACED IN ANY MANNER EXCEPT OCEC APPROVED GUY AND ANCHORS.

5. CONSUMER FACILITIES SHALL COMPLY WITH NATIONAL ELECTRIC CODE.

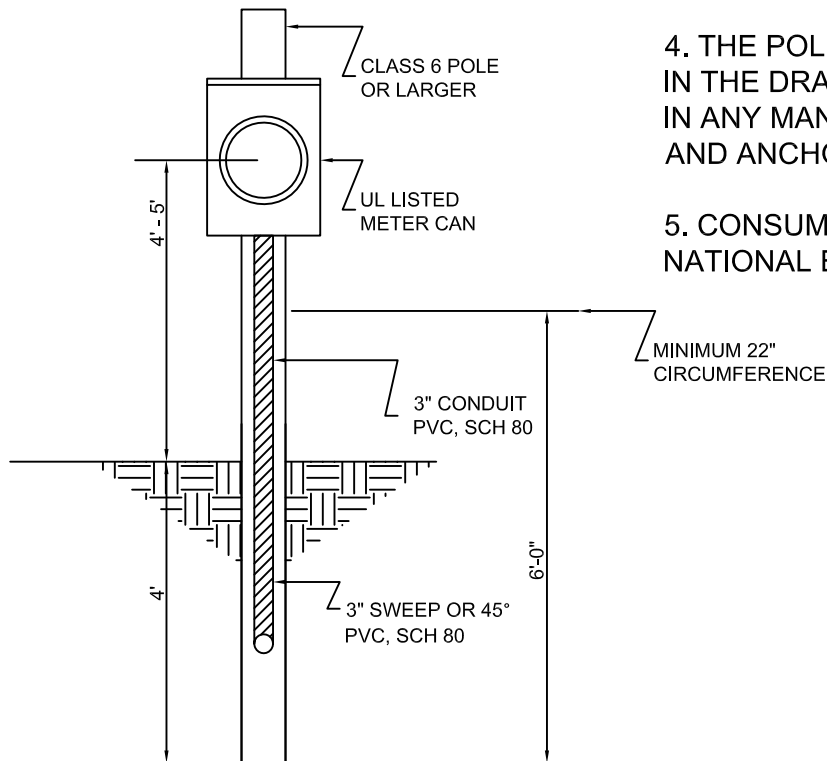

UNDERGROUND PERMANENT/TEMPORARY SINGLE-PHASE OR  
TEMPORARY THREE-PHASE SERVICE POLE

# OTERO COUNTY ELECTRIC COOPERATIVE URD METER POLE SPEC SHEET

METER POLE SHALL NOT BE INSTALLED WITHIN 15' OF CENTERLINE OF OCEC POWER LINES OR EQUIPMENT

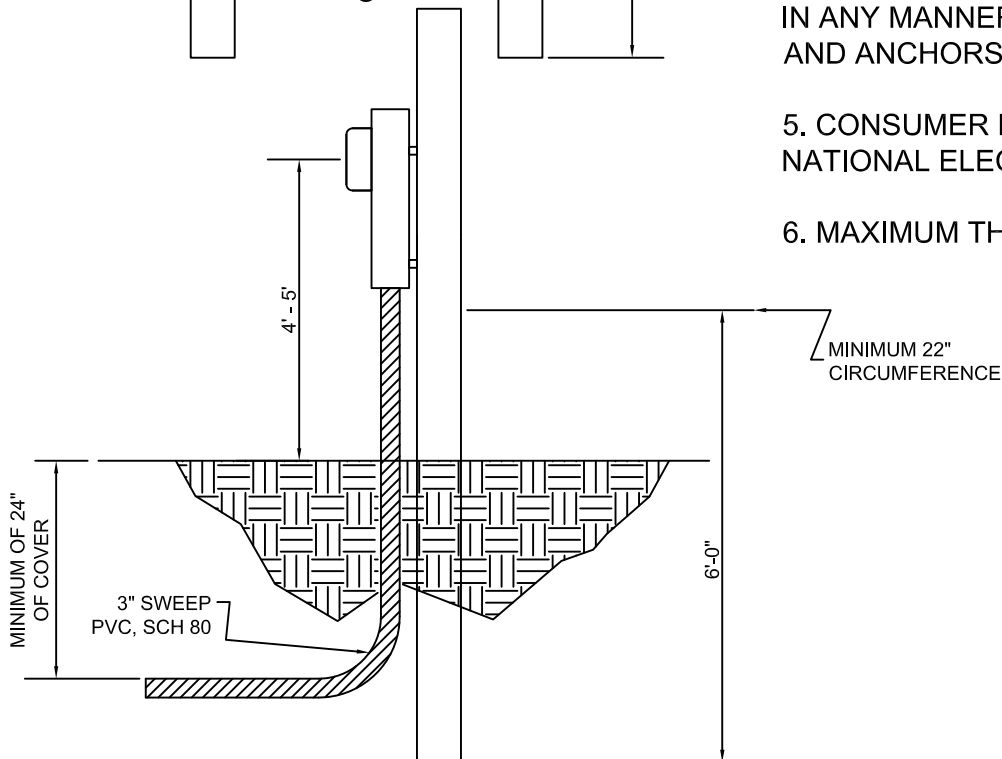
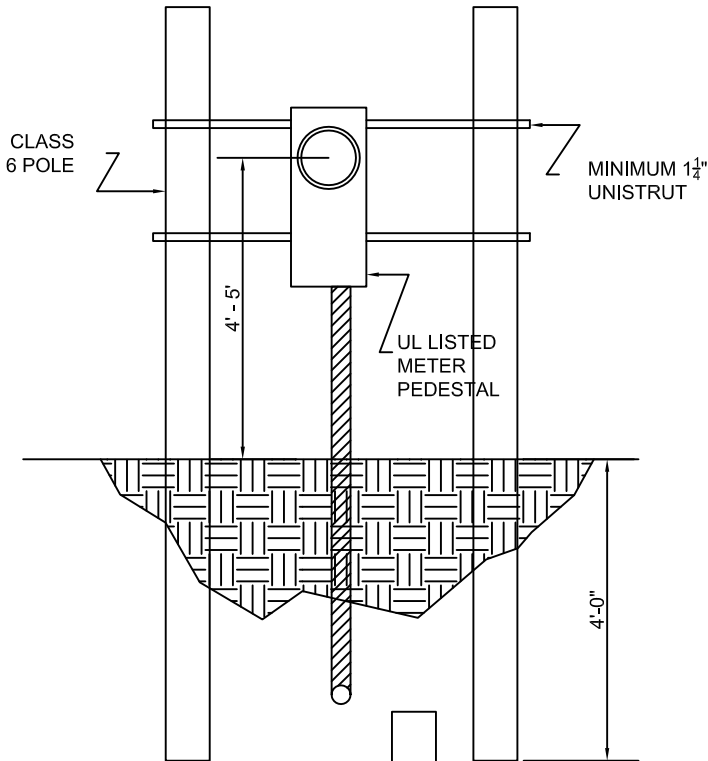

1. OCEC SHALL APPROVE LOCATION OF METER POLE PRIOR TO INSTALLATION. OCEC SHALL DETERMINE THE MAXIMUM SERVICE DISTANCE, WHICH WILL DEPEND ON CLEARANCE, CONDUCTOR REQUIREMENTS AND LOAD.

2. METER POLE / METER LOOP INSTALLATION SHALL PASS STATE OR LOCAL ELECTRICAL INSPECTION PRIOR TO CONNECTION. METER POLES SERVING MOBILE HOMES WILL NOT BE CONNECTED UNTIL THE MOBILE HOME PASSES INSPECTION BY THE STATE OR LOCAL MOBILE HOME INSPECTOR.

3. POLE CIRCUMFERENCE SHALL BE A MINIMUM OF 22", MEASURED 6' FROM THE BUTT OF THE POLE AND A CLASS 6 POLE OR LARGER AND MUST BE TREATED.

4. THE POLE SHALL BE SET TO DEPTH SHOWN IN THE DRAWING AND SHALL NOT BE BRACED IN ANY MANNER EXCEPT OCEC APPROVED GUY AND ANCHORS.

5. CONSUMER FACILITIES SHALL COMPLY WITH NATIONAL ELECTRIC CODE.

6. MAXIMUM THREE METER SOCKETS PER SIDE.

UNDERGROUND PERMANENT/TEMPORARY SINGLE-PHASE OR  
TEMPORARY THREE-PHASE SERVICE POLE